



GE2 HC High Cyclicity

2-WAY HIGH PRESSURE BALL VALVES

1.000.000 CYCLES

Edition. 21.3

CS Carbon Steel

- Type: ball valve 2 way high cycles
- Sizes: from DN6 up to DN32
- Ends: BSP-NPT-SAE
- Pressure: up to PN500
- Temp range: from -20°C to +100°C
- Treatment: Galvanized

SS Stainless Steel

- Type: ball valve 2 way high cycles
- Sizes: from DN6 up to DN32
- Ends: BSP-NPT-SAE
- Pressure: up to PN500
- Temp range: from -30°C to +100°C

STANDARD COMPOSITION OF VALVE

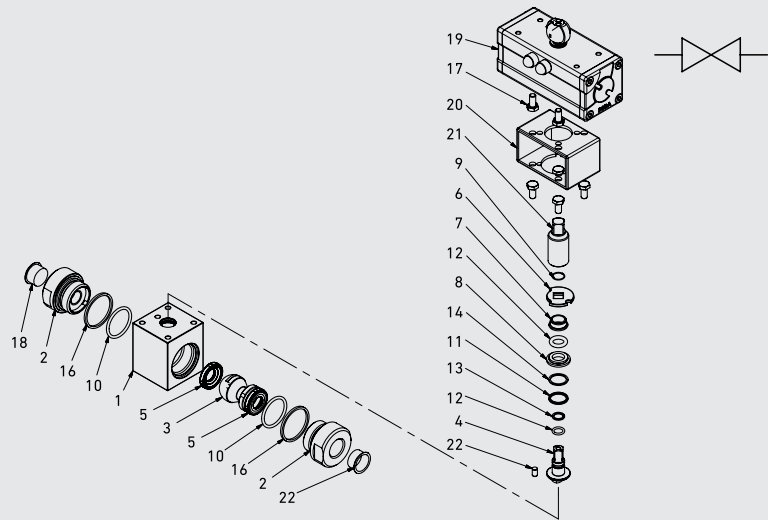

POS	DESCRIPTION	Q.TY		MATERIAL		POS	DESCRIPTION	Q.TY		MATERIAL	
		DN10-13	DN20-25-32	CS Carbon Steel	SS Stainless Steel			DN10-13	DN20-25-32	CS Carbon Steel	SS Stainless Steel
1	Body	1	1	1,0737	1,4404	12	Stem o-ring	1	/	NBR	NBR
2	Adapter	2	2	1,0460	1,4404	13	Stem Back-up	1	1	PTFE	PTFE
3	Ball	1	1	1,4404	1,4404	14	Stem Back-up	1	/	PTFE	PTFE
4	Stem	1	1	1,4542	1,4542	15	Stem quad-ring	1	1	NBR	NBR
5	Ball seat	2	2	PA612G	PA612G	16	Closure gasket	2	2	GRAPHITE	GRAPHITE
6	Washer	1	1	1,0116	1,0116	17	Screws	8	8	ISO 4017 8.8	ISO 4017 8.8
7	Upper Bushing	1	1	POM - A1000	POM -A1000	18	Caps	2	2	PVC	PVC
8	Lower Bushing	1	1	POM - A1000	POM -A1000	19	Actuator	1	1	N/A	N/A
9	Seeger	1	1	1,4404	1,4404	20	Connector	1	1	1,0737	1,0737
10	Adapter o-ring	2	2	NBR	NBR	21	Joint	1	1	1,0737	1,0737
11	Stem o-ring	1	1	NBR	NBR	22	Pin	1	1	1,0737	1,4404

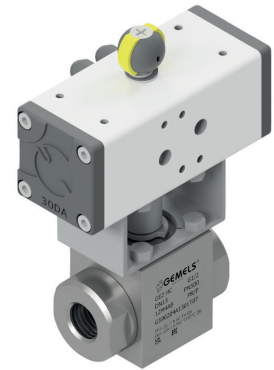
 STANDARD DESIGN: BARE STEM
WITH ACTUATOR HOLES

CODE DESCRIPTION STRUCTURE

GE2 HC **G 1/2** **DN13** **1** **2** **M** **4** **A** **B**

Type and way of valve

GE2 HC 2-way

Ends

GAS DIN/ISO 228 BSP	NPT ANSI /ASME B1.20.1	SAE J1926-1
G 1/4	N 1/4	SAE4
G 3/8	N 3/8	SAE6
G 1/2	N 1/2	SAE8
G 3/4	N 3/4	SAE12
G 1	N 1	SAE16
G 1 1/4	N 1 1/4	SAE20

Size

from DN6 to DN32

Body Material

- 1 = 1,0737
- 4 = 1,4404

Adapter material

- 2 = 1,0460
- 4 = 1,4404

Stem material

- M = 1,4542
- M = 1,4542

Ball Material

- 4 = 1,4404
- 4 = 1,4404

Seat material

A = POM D = PEEK* G = PA612* K = GEMPTFE* C = PTFE*

Seal material

B = NBR E = FKM* F = EPDM* L = MVQ*

*On request

- Pneumatic and electrical actuator

For further special requests please consult our technical/commercial service.

STANDARD DESIGN: BARE STEM WITH ACTUATOR HOLES

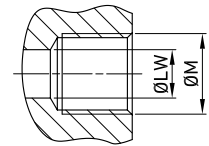
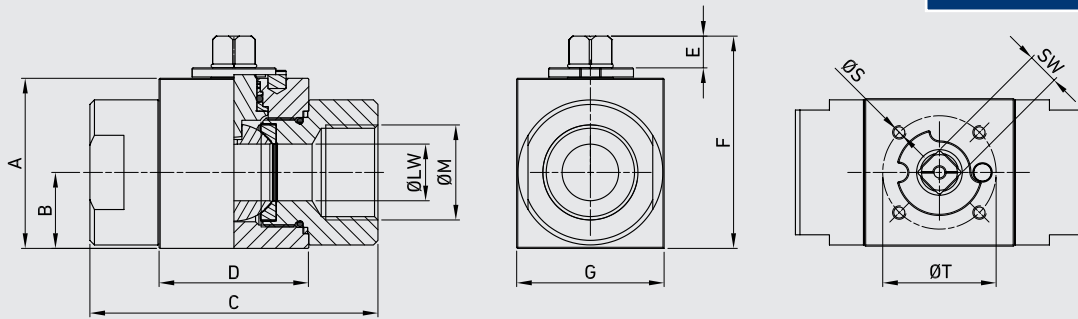

GE2 HC DIN/ISO 228 BSP

TYPE	DN	PN	A	B	C	D	E	F	G	ØM	ØS	ØT	ISO5211	SW	ØLW	WEIGHT	ITEM CODE	
																	CS	SS
GE2 HC G 1/4	6	MPa 50	mm 57	24,5	73	44	11	71,3	49	G 1/4	M6	50	F05	9	10	kg 0,505	G590202A1301TAA	G590202A2P01TAA
		Psi 7250	inch 2,24	0,96	2,87	1,73	0,43	2,81	1,93							1,97		
GE2 HC G 3/8	10	MPa 50	mm 57	24,5	73	44	11	71,3	49	G 3/8	M6	50	F05	9	10	kg 0,744	G590203A1301TAA	G590203A2P01TAA
		Psi 7250	inch 2,24	0,96	2,87	1,73	0,43	2,81	1,93							1,97		
GE2 HC G 1/2	13	MPa 50	mm 57	23,5	81	48	11	71,3	49	G 1/2	M6	50	F05	9	13	kg 1,238	G590204A1301TAA	G590204A2P01TAA
		Psi 7250	inch 2,24	0,93	3,19	1,89	0,43	2,81	1,93							1,97		
GE2 HC G 3/4	20	MPa 40	mm 65	27	98	62	14	83,7	55	G 3/4	M6	50	F05	14	20	kg 1,818	G590205A1301RAA	G590205A2P01RAA
		Psi 5800	inch 2,56	1,06	3,86	2,44	0,55	3,30	2,17							1,97		
GE2 HC G 1	25	MPa 35	mm 75	33,5	106	66	14	93,6	65	G 1	M6	50	F05	14	25	kg 2,323	G590206A1301PAA	G590206A2P01PAA
		Psi 5075	inch 2,95	1,32	4,17	2,60	0,55	3,69	2,56							1,97		
GE2 HC G 1 1/4 R	25	MPa 35	mm 75	33,5	127	66	14	93,6	65	G1 1/4	M6	50	F05	14	25	kg 2,573	G590207R1301PAA	G590207R2P01PAA
		Psi 5075	inch 2,95	1,32	5,00	2,60	0,55	3,69	2,56							1,97		
GE2 HC G 1 1/4	32	MPa 35	mm 87	40,75	127	83	14	93,6	80	G1 1/4	M8	70	F07	14	32	kg 2,890	G590207A1301PAA	G590207A2P01PAA
		Psi 5075	inch 3,43	1,60	5,00	3,27	0,55	3,69	3,15							2,76		

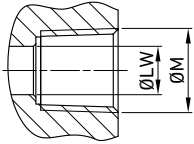
GE2 HC ANSI/ASME B1.20.1 NPT

																	CS	SS
																	Carbon Steel	Stainless Steel
TYPE	DN	PN	A	B	C	D	E	F	G	ØM	ØS	ØT	ISO5211	SW	ØLW	WEIGHT	ITEM CODE	
GE2 HC N 1/4	6	MPa 50	mm 57	24,5	73	44	11	71,3	49	N 1/4	M6	50	F05	9	10	kg 0,505	G590902A1301TAA	G590902A2P01TAA
		Psi 7250	inch 2,24	0,96	2,87	1,73	0,43	2,81	1,93									
GE2 HC N 3/8	10	MPa 50	mm 57	24,5	73	44	11	71,3	49	N 3/8	M6	50	F05	9	10	kg 0,744	G590903A1301TAA	G590903A2P01TAA
		Psi 7250	inch 2,24	0,96	2,87	1,73	0,43	2,81	1,93									
GE2 HC N 1/2	13	MPa 50	mm 57	23,5	81	48	11	71,3	49	N 1/2	M6	50	F05	9	13	kg 1,238	G590904A1301TAA	G590904A2P01TAA
		Psi 7250	inch 2,24	0,93	3,19	1,89	0,43	2,81	1,93									
GE2 HC N 3/4	20	MPa 40	mm 65	27	98	62	14	83,7	55	N 3/4	M6	50	F05	14	20	kg 1,818	G590905A1301RAA	G590905A2P01RAA
		Psi 5800	inch 2,56	1,06	3,86	2,44	0,55	3,30	2,17									
GE2 HC N 1	25	MPa 35	mm 75	33,5	106	66	14	93,6	65	N 1	M6	50	F05	14	25	kg 2,323	G590906A1301PAA	G590906A2P01PAA
		Psi 5075	inch 2,95	1,32	4,17	2,60	0,55	3,69	2,56									
GE2 HC N 1/4 R	25	MPa 35	mm 75	33,5	127	66	14	93,6	65	N 1/4	M6	50	F05	14	25	kg 2,573	G590907R1301PAA	G590907R2P01PAA
		Psi 5075	inch 2,95	1,32	5,00	2,60	0,55	3,69	2,56									
GE2 HC N 1 1/4	32	MPa 35	mm 87	40,75	127	83	14	93,6	80	N 1 1/4	M8	70	F07	14	32	kg 2,890	G590907A1301PAA	G590907A2P01PAA
		Psi 5075	inch 3,43	1,60	5,00	3,27	0,55	3,69	3,15									

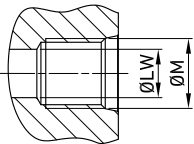
GE2 HC SAE J1926-1

																	CS	SS
																	Carbon Steel	Stainless Steel
TYPE	DN	PN	A	B	C	D	E	F	G	ØM	ØS	ØT	ISO5211	SW	ØLW	WEIGHT	ITEM CODE	
GE2 HC SAE4	6	MPa 50	mm 57	24,5	73	44	11	71,3	49	7/16	M6	50	F05	9	10	kg 0,505	G590B02A1301TAA	G590B02A2P01TAA
		Psi 7250	inch 2,24	0,96	2,87	1,73	0,43	2,81	1,93									
GE2 HC SAE6	10	MPa 50	mm 57	24,5	73	44	11	71,3	49	9/16	M6	50	F05	9	10	kg 0,744	G590B03A1301TAA	G590B03A2P01TAA
		Psi 7250	inch 2,24	0,96	2,87	1,73	0,43	2,81	1,93									
GE2 HC SAE8	13	MPa 50	mm 57	23,5	81	48	11	71,3	49	3/4	M6	50	F05	9	13	kg 1,238	G590B04A1301TAA	G590B04A2P01TAA
		Psi 7250	inch 2,24	0,93	3,19	1,89	0,43	2,81	1,93									
GE2 HC SAE12	20	MPa 40	mm 65	27	98	62	14	83,7	55	1 1/16	M6	50	F05	14	20	kg 1,818	G590B05A1301RAA	G590B05A2P01RAA
		Psi 5800	inch 2,56	1,06	3,86	2,44	0,55	3,30	2,17									
GE2 HC SAE16	25	MPa 35	mm 75	33,5	106	66	14	93,6	65	1 5/16	M6	50	F05	14	25	kg 2,323	G590B06A1301PAA	G590B06A2P01PAA
		Psi 5075	inch 2,95	1,32	4,17	2,60	0,55	3,69	2,56									
GE2 HC SAE20R	25	MPa 35	mm 75	33,5	127	66	14	93,6	65	1 5/8	M6	50	F05	14	25	kg 2,573	G590B07R1301PAA	G590B07R2P01PAA
		Psi 5075	inch 2,95	1,32	5,00	2,60	0,55	3,69	2,56									
GE2 HC SAE20	32	MPa 35	mm 87	40,75	127	83	14	93,6	80	1 5/8	M8	70	F07	14	32	kg 2,890	G590B07A1301PAA	G590B07A2P01PAA
		Psi 5075	inch 3,43	1,60	5,00	3,27	0,55	3,69	3,15									

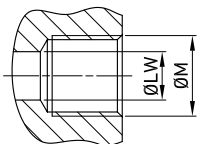
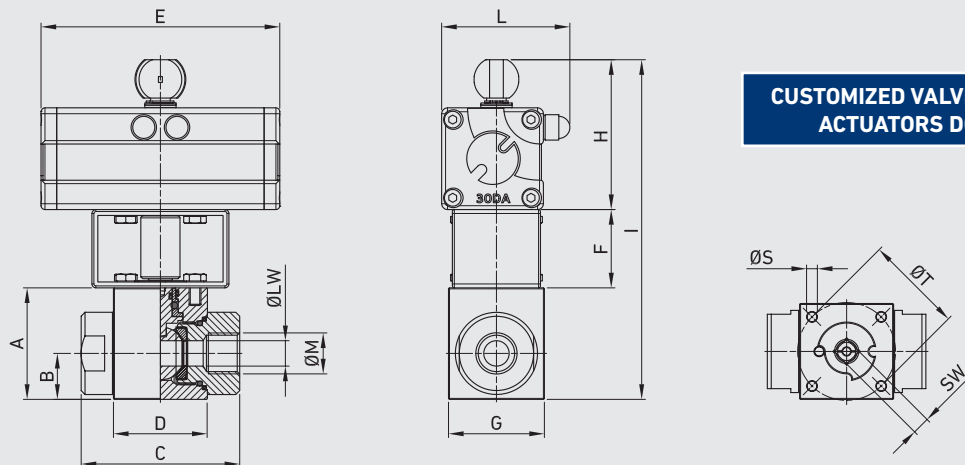

GE2 HC DIN/ISO 228 BSP

TYPE	DN	PN	A	B	C	D	E	F	G	H	I	L	ØM	ØS	ØT	ISO5211	SW	ØLW	WEIGHT
GE2 HC G 1/4	6	MPa 50	mm 57	24,5	73	44	122	40	49	76,6	173,6	65,5	G 1/4	M6	50	F05	9	10	kg 1,113
		Psi 7250	inch 2,24	0,96	2,87	1,73	4,80	1,57	1,93	3,02	6,83	2,58			1,97		0,35	0,39	lb 2,45
GE2 HC G 3/8	10	MPa 50	mm 57	24,5	73	44	122	40	49	76,6	173,6	65,5	G 3/8	M6	50	F05	9	10	kg 1,0610
		Psi 7250	inch 2,24	0,96	2,87	1,73	4,80	1,57	1,93	3,02	6,83	2,58			1,97		0,35	0,39	lb 2,34
GE2 HC G 1/2	13	MPa 50	mm 57	23,5	81	48	122	40	49	76,6	173,6	65,5	G 1/2	M6	50	F05	9	13	kg 1,187
		Psi 7250	inch 2,24	0,93	3,19	1,89	4,80	1,57	1,93	3,02	6,83	2,58			1,97		0,35	0,51	lb 2,62
GE2 HC G 3/4	20	MPa 40	mm 65	27	98	62	151	40	55	89,6	194,6	80,6	G 3/4	M6	50	F05	14	20	kg 1,9350
		Psi 5800	inch 2,56	1,06	3,86	2,44	5,94	1,57	2,17	3,53	7,66	3,17			1,97		0,55	0,79	lb 4,27
GE2 HC G 1	25	MPa 35	mm 75	33,5	106	66	151	40	65	89,6	204,6	80,6	G 1	M6	50	F05	14	25	kg 2,787
		Psi 5075	inch 2,95	1,32	4,17	2,60	5,94	1,57	2,56	3,53	8,06	3,17			1,97		0,55	0,98	lb 6,14
GE2 HC G 1 1/4 R	25	MPa 35	mm 75	33,5	127	66	151	40	65	89,6	204,6	80,6	G1 1/4	M6	50	F05	14	25	kg 4,768
		Psi 5075	inch 2,95	1,32	5,00	2,60	5,94	1,57	2,56	3,53	8,06	3,17			1,97		0,55	0,98	lb 10,51
GE2 HC G 1 1/4	32	MPa 35	mm 87	40,75	127	83	197	40	80	105	232	95,6	G1 1/4	M8	70	F07	14	32	kg 4,933
		Psi 5075	inch 3,43	1,60	5,00	3,27	7,76	1,57	3,15	4,13	9,13	3,76			2,76		0,55	1,26	lb 10,88

Customized valves with selected actuators

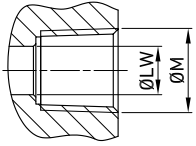

GE2 HC ANSI/ASME B1.20.1 NPT

TYPE	DN	PN	A	B	C	D	E	F	G	H	I	L	ØM	ØS	ØT	ISO5211	SW	ØLW	WEIGHT	
GE2 HC N 1/4	6	MPa 50	mm	57	24,5	73	44	122	40	49	76,6	173,6	65,5	N 1/4	M6	50	F05	9	10	kg 1,113
		Psi 7250	inch	2,24	0,96	2,87	1,73	4,80	1,57	1,93	3,02	6,83	2,58			1,97		0,35	0,39	lb 2,45
GE2 HC N 3/8	10	MPa 50	mm	57	24,5	73	44	122	40	49	76,6	173,6	65,5	N 3/8	M6	50	F05	9	10	kg 1,2100
		Psi 7250	inch	2,24	0,96	2,87	1,73	4,80	1,57	1,93	3,02	6,83	2,58			1,97		0,35	0,39	lb 2,67
GE2 HC N 1/2	13	MPa 50	mm	57	23,5	81	48	122	40	49	76,6	173,6	65,5	N 1/2	M6	50	F05	9	13	kg 1,184
		Psi 7250	inch	2,24	0,93	3,19	1,89	4,80	1,57	1,93	3,02	6,83	2,58			1,97		0,35	0,51	lb 2,61
GE2 HC N 3/4	20	MPa 40	mm	65	27	98	62	151	40	55	89,6	194,6	80,6	N 3/4	M6	50	F05	14	20	kg 2,04
		Psi 5800	inch	2,56	1,06	3,86	2,44	5,94	1,57	2,17	3,53	7,66	3,17			1,97		0,55	0,79	lb 4,50
GE2 HC N 1	25	MPa 35	mm	75	33,5	106	66	151	40	65	89,6	204,6	80,6	N 1	M6	50	F05	14	25	kg 3,08
		Psi 5075	inch	2,95	1,32	4,17	2,60	5,94	1,57	2,56	3,53	8,06	3,17			1,97		0,55	0,98	lb 6,79
GE2 HC N 1/4 R	25	MPa 35	mm	75	33,5	127	66	151	40	65	89,6	204,6	80,6	N 1 1/4	M6	50	F05	14	25	kg 3,08
		Psi 5075	inch	2,95	1,32	5,00	2,60	5,94	1,57	2,56	3,53	8,06	3,17			1,97		0,55	0,98	lb 6,79
GE2 HC N 1 1/4	32	MPa 35	mm	87	40,75	127	83	197	40	80	105	232	95,6	N 1 1/4	M8	70	F07	14	32	kg 4,933
		Psi 5075	inch	3,43	1,60	5,00	3,27	7,76	1,57	3,15	4,13	9,13	3,76			2,76		0,55	1,26	lb 10,88

Customized valves with selected actuators

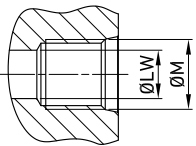

GE2 HC SAE J1926-1

TYPE	DN	PN	A	B	C	D	E	F	G	H	I	L	ØM	ØS	ØT	ISO5211	SW	ØLW	WEIGHT	
GE2 HC SAE4	6	MPa 50	mm	57	24,5	73	44	122	40	49	76,6	173,6	65,5	7/16	M6	50	F05	9	10	kg 1,113
		Psi 7250	inch	2,24	0,96	2,87	1,73	4,80	1,57	1,93	3,02	6,83	2,58	UNF		1,97		0,35	0,39	lb 2,45
GE2 HC SAE6	10	MPa 50	mm	57	24,5	73	44	122	40	49	76,6	173,6	65,5	9/16	M6	50	F05	9	10	kg 1,2100
		Psi 7250	inch	2,24	0,96	2,87	1,73	4,80	1,57	1,93	3,02	6,83	2,58	UNF		1,97		0,35	0,39	lb 2,67
GE2 HC SAE8	13	MPa 50	mm	57	23,5	81	48	122	40	49	76,6	173,6	65,5	3/4	M6	50	F05	9	13	kg 1,187
		Psi 7250	inch	2,24	0,93	3,19	1,89	4,80	1,57	1,93	3,02	6,83	2,58	UNF		1,97		0,35	0,51	lb 2,62
GE2 HC SAE12	20	MPa 40	mm	65	27	98	62	151	40	55	89,6	194,6	80,6	1 1/16	M6	50	F05	14	20	kg 1,9350
		Psi 5800	inch	2,56	1,06	3,86	2,44	5,94	1,57	2,17	3,53	7,66	3,17	UNF		1,97		0,55	0,79	lb 4,27
GE2 HC SAE16	25	MPa 35	mm	75	33,5	106	66	151	40	65	89,6	204,6	80,6	1 5/16	M6	50	F05	14	25	kg 2,787
		Psi 5075	inch	2,95	1,32	4,17	2,60	5,94	1,57	2,56	3,53	8,06	3,17	UNF		1,97		0,55	0,98	lb 6,14
GE2 HC SAE20R	25	MPa 35	mm	75	33,5	127	66	151	40	65	89,6	204,6	80,6	1 5/8	M6	50	F05	14	25	kg 4,768
		Psi 5075	inch	2,95	1,32	5,00	2,60	5,94	1,57	2,56	3,53	8,06	3,17	UNF		1,97		0,55	0,98	lb 10,51
GE2 HC SAE20	32	MPa 35	mm	87	40,75	127	83	197	40	80	105	232	95,6	1 5/8	M8	70	F07	14	32	kg 4,934
		Psi 5075	inch	3,43	1,60	5,00	3,27	7,76	1,57	3,15	4,13	9,13	3,76	UNF		2,76		0,55	1,26	lb 10,88

Customized valves with selected actuators

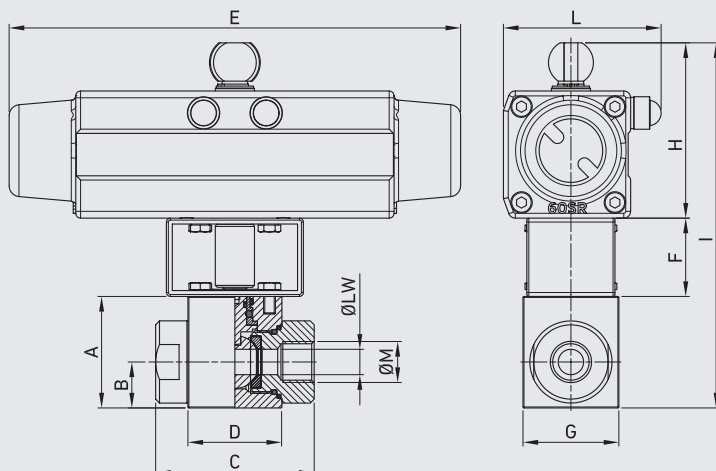

CUSTOMIZED VALVES WITH SELECTED ACTUATORS SPRING RETURN

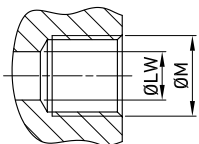
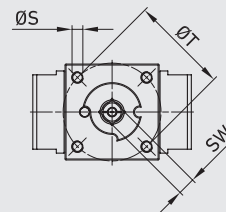

GE2 HC DIN/ISO 228 BSP

TYPE	DN	PN	A	B	C	D	E	F	G	H	I	L	ØM	ØS	ØT	ISO5211	SW	ØLW	WEIGHT
GE2 HC G 1/4	6	MPa 50	mm 57	24,5	73	44	231	40	49	89,6	186,6	80,6	G 1/4	M6	50	F05	9	10	kg 1,113
		Psi 7250	inch 2,24	0,96	2,87	1,73	9,09	1,57	1,93	3,53	7,35	3,17			1,97		0,35	0,39	lb 2,45
GE2 HC G 3/8	10	MPa 50	mm 57	24,5	73	44	231	40	49	89,6	186,6	80,6	G 3/8	M6	50	F05	9	10	kg 1,0610
		Psi 7250	inch 2,24	0,96	2,87	1,73	9,09	1,57	1,93	3,53	7,35	3,17			1,97		0,35	0,39	lb 2,34
GE2 HC G 1/2	13	MPa 50	mm 57	23,5	81	48	231	40	49	89,6	186,6	80,6	G 1/2	M6	50	F05	9	13	kg 1,187
		Psi 7250	inch 2,24	0,93	3,19	1,89	9,09	1,57	1,93	3,53	7,35	3,17			1,97		0,35	0,51	lb 2,62
GE2 HC G 3/4	20	MPa 40	mm 65	27	98	62	300	40	55	105	210	96	G 3/4	M6	50	F05	14	20	kg 1,9350
		Psi 5800	inch 2,56	1,06	3,86	2,44	11,81	1,57	2,17	4,13	8,27	3,78			1,97		0,55	0,79	lb 4,27
GE2 HC G 1	25	MPa 35	mm 75	33,5	106	66	300	40	65	105	220	96	G 1	M6	50	F05	14	25	kg 2,787
		Psi 5075	inch 2,95	1,32	4,17	2,60	11,81	1,57	2,56	4,13	8,66	3,78			1,97		0,55	0,98	lb 6,14
GE2 HC G 1 1/4 R	25	MPa 35	mm 75	33,5	127	66	300	40	65	105	220	96	G1 1/4	M6	50	F05	14	25	kg 4,768
		Psi 5075	inch 2,95	1,32	5,00	2,60	11,81	1,57	2,56	4,13	8,66	3,78			1,97		0,55	0,98	lb 10,51
GE2 HC G 1 1/4	32	MPa 35	mm 87	40,75	127	83	410	40	80	135	262	131	G1 1/4	M8	70	F07	14	32	kg 4,933
		Psi 5075	inch 3,43	1,60	5,00	3,27	16,14	1,57	3,15	5,31	10,31	5,16			2,76		0,55	1,26	lb 10,88

Customized valves with selected actuators

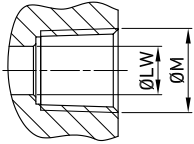

GE2 HC ANSI/ASME B1.20.1 NPT

TYPE	DN	PN	A	B	C	D	E	F	G	H	I	L	ØM	ØS	ØT	ISO5211	SW	ØLW	WEIGHT	
GE2 HC N 1/4	6	MPa 50	mm	57	24,5	73	44	231	40	49	89,6	186,6	80,6	N 1/4	M6	50	F05	9	10	kg 1,113
		Psi 7250	inch	2,24	0,96	2,87	1,73	9,09	1,57	1,93	3,53	7,35	3,17			1,97		0,35	0,39	lb 2,45
GE2 HC N 3/8	10	MPa 50	mm	57	24,5	73	44	231	40	49	89,6	186,6	80,6	N 3/8	M6	50	F05	9	10	kg 1,2100
		Psi 7250	inch	2,24	0,96	2,87	1,73	9,09	1,57	1,93	3,53	7,35	3,17			1,97		0,35	0,39	lb 2,67
GE2 HC N 1/2	13	MPa 50	mm	57	23,5	81	48	231	40	49	89,6	186,6	80,6	N 1/2	M6	50	F05	9	13	kg 1,184
		Psi 7250	inch	2,24	0,93	3,19	1,89	9,09	1,57	1,93	3,53	7,35	3,17			1,97		0,35	0,51	lb 2,61
GE2 HC N 3/4	20	MPa 40	mm	65	27	98	62	300	40	55	105	210	96	N 3/4	M6	50	F05	14	20	kg 2,04
		Psi 5800	inch	2,56	1,06	3,86	2,44	11,81	1,57	2,17	4,13	8,27	3,78			1,97		0,55	0,79	lb 4,50
GE2 HC N 1	25	MPa 35	mm	75	33,5	106	66	300	40	65	105	220	96	N 1	M6	50	F05	14	25	kg 3,08
		Psi 5075	inch	2,95	1,32	4,17	2,60	11,81	1,57	2,56	4,13	8,66	3,78			1,97		0,55	0,98	lb 6,79
GE2 HC N 1/4 R	25	MPa 35	mm	75	33,5	127	66	300	40	65	105	220	96	N 1 1/4	M6	50	F05	14	25	kg 3,08
		Psi 5075	inch	2,95	1,32	5,00	2,60	11,81	1,57	2,56	4,13	8,66	3,78			1,97		0,55	0,98	lb 6,79
GE2 HC N 1 1/4	32	MPa 35	mm	87	40,75	127	83	410	40	80	135	262	131	N 1 1/4	M8	70	F07	14	32	kg 4,933
		Psi 5075	inch	3,43	1,60	5,00	3,27	16,14	1,57	3,15	5,31	10,31	5,16			2,76		0,55	1,26	lb 10,88

Customized valves with selected actuators

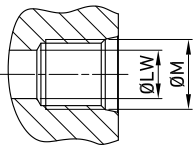

GE2 HC SAE J1926-1

TYPE	DN	PN	A	B	C	D	E	F	G	H	I	L	ØM	ØS	ØT	ISO5211	SW	ØLW	WEIGHT	
GE2 HC SAE4	6	MPa 57	mm	57	24,5	73	44	231	40	49	89,6	186,6	80,6	7/16	M6	50	F05	9	10	kg 1,113
		Psi 2,24	inch	2,24	0,96	2,87	1,73	9,09	1,57	1,93	3,53	7,35	3,17	UNF		1,97		0,35	0,39	lb 2,45
GE2 HC SAE6	10	MPa 57	mm	57	24,5	73	44	231	40	49	89,6	186,6	80,6	9/16	M6	50	F05	9	10	kg 1,2100
		Psi 2,24	inch	2,24	0,96	2,87	1,73	9,09	1,57	1,93	3,53	7,35	3,17	UNF		1,97		0,35	0,39	lb 2,67
GE2 HC SAE8	13	MPa 57	mm	57	23,5	81	48	231	40	49	89,6	186,6	80,6	3/4	M6	50	F05	9	13	kg 1,187
		Psi 2,24	inch	2,24	0,93	3,19	1,89	9,09	1,57	1,93	3,53	7,35	3,17	UNF		1,97		0,35	0,51	lb 2,62
GE2 HC SAE12	20	MPa 65	mm	65	27	98	62	300	40	55	105	210	96	1 1/16	M6	50	F05	14	20	kg 1,9350
		Psi 2,56	inch	2,56	1,06	3,86	2,44	11,81	1,57	2,17	4,13	8,27	3,78	UNF		1,97		0,55	0,79	lb 4,27
GE2 HC SAE16	25	MPa 75	mm	75	33,5	106	66	300	40	65	105	220	96	1 5/16	M6	50	F05	14	25	kg 2,787
		Psi 2,95	inch	2,95	1,32	4,17	2,60	11,81	1,57	2,56	4,13	8,66	3,78	UNF		1,97		0,55	0,98	lb 6,14
GE2 HC SAE20R	25	MPa 75	mm	75	33,5	127	66	300	40	65	105	220	96	1 5/8	M6	50	F05	14	25	kg 4,768
		Psi 2,95	inch	2,95	1,32	5,00	2,60	11,81	1,57	2,56	4,13	8,66	3,78	UNF		1,97		0,55	0,98	lb 10,51
GE2 HC SAE20	32	MPa 87	mm	87	40,75	127	83	410	40	80	135	262	131	1 5/8	M8	70	F07	14	32	kg 4,934
		Psi 3,43	inch	3,43	1,60	5,00	3,27	16,14	1,57	3,15	5,31	10,31	5,16	UNF		2,76		0,55	1,26	lb 10,88

Customized valves with selected actuators