



# GPK2

## 2-WAY HIGH PRESSURE BALL VALVES

Edition. 21.2

### CS Carbon Steel

- Type: manifold
- Sizes: from DN6 up to DN50
- Ends: Drilling pattern Gemels
- Pressure: up to PN500
- Temp range: from -20°C to +100°C
- Treatment: Galvanized

### STANDARD COMPOSITION OF VALVE

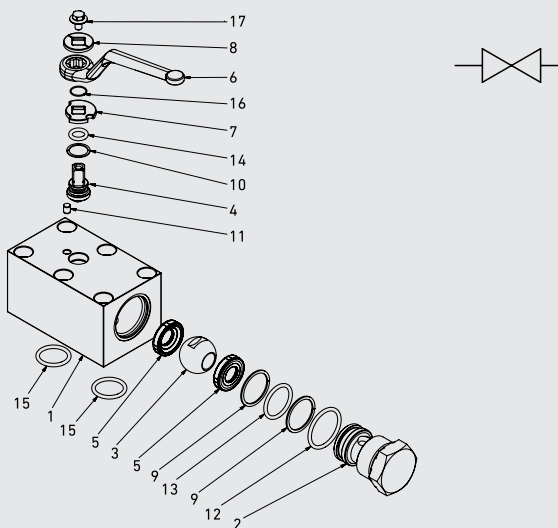

POS	DESCRIPTION	Q.TY	CS Carbon Steel		POS	DESCRIPTION	Q.TY	CS Carbon Steel	
				MATERIAL					MATERIAL
1	Body	1		1,0737	11	Seeger	1		1,4404
2	Adapter	1		1,0737	12	Adapter o-ring	1		NBR
3	Ball	1		1,0737	13	Adapter o-ring	1		NBR
4	Stem	1		1,0737	14	Body o-ring	2		NBR
5	Ball seat	2		POM	15	Stem o-ring	1		NBR
6	Handle	1		ZINC	16	Screw	1		Din 6921 8.8
7	Washer	1		1,0116	17	Back-Up	2		PTFE
8	Washer	1		1,0116					
9	Stem ring	1		POM					
10	Pin	1		1,0737					



## CODE DESCRIPTION STRUCTURE

GPK2	DN13	1	1	1	1	A	B
------	------	---	---	---	---	---	---

### Type and way of valve

GPK2 2-way

### Size

from DN6 to DN50

### Body Material

● 1 = 1,0737 4 = 1,4404\*

### Adapter material

● 1 = 1,0737 4 = 1,4404\*

### Stem material

● 1 = 1,0737 4 = 1,4404\*

### Ball Material

● 1 = 1,0737 4 = 1,4404\*

### Seat material

A = POM D = PEEK\* G = PA612\* K = GEMPTFE\* C = PTFE\*

### Seal material

B = NBR E = FKM\*

### \*On request

- Reduced bore
- Pressure class up to PN50 MPa
- Pneumatic and electrical actuator
- Locking device

For further special requests please consult our technical/commercial service.

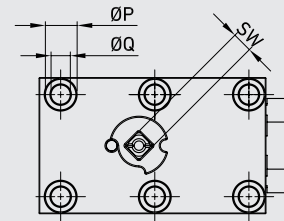
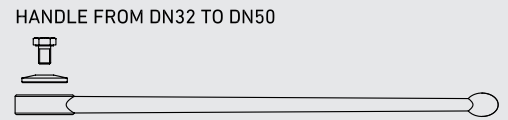
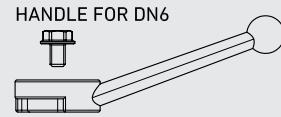
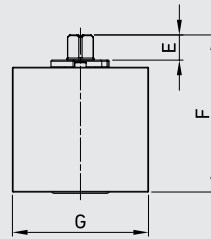
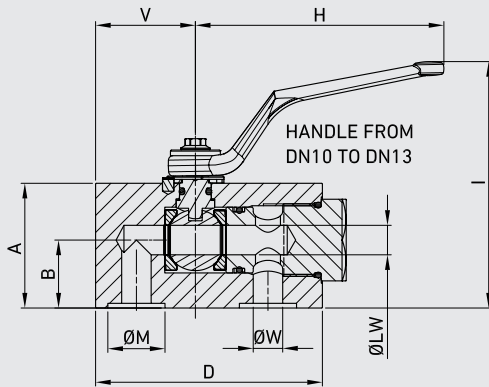
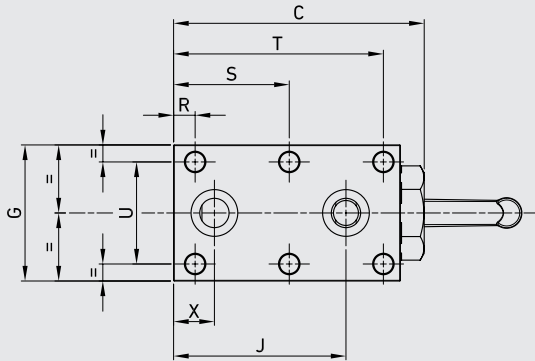

GPK2

CS  
Carbon Steel

TYPE	DN	PN	A	B	C	D	E	F	G	H	I	J	ØM	ØP	ØQ	R	S	T	U	V	ØW	X	SW	ØLW	WEIGHT	ITEM CODE
GPK2	6	MPa 50	mm 35	22,5	64,5	58	7,5	42,5	40	60	61	44	11,8	10,5	6,5	9	-	44,5	27	26,5	6	9,5	6	6	kg 0,593	GP200T15011A000
		Psi 7250	inch 1,38	0,89	2,54	2,28	0,30	1,67	1,57	2,36	2,40	1,73	0,46	0,41	0,26	0,35	-	1,75	1,06	1,04	0,24	0,37	0,24	0,24	lb 1,31	
GPK2	10	MPa 50	mm 45	22,5	79,5	70	11	59	55	110	101	54	14,9	13,5	8,5	7,5	-	62,5	40	28,75	9,8	10	9	10	kg 1,304	GP200T25011A000
		Psi 7250	inch 1,77	0,89	3,13	2,76	0,43	2,32	2,17	4,33	3,98	2,13	0,59	0,53	0,33	0,30	-	2,46	1,57	1,13	0,39	0,39	0,35	0,39	lb 2,87	
GPK2	13	MPa 40	mm 55	30	110,5	100	11	69	60	110	111	76	24,9	13,5	8,5	9,5	51	92,5	45	44	13	18	9	13	kg 2,387	GP200T34011A000
		Psi 5800	inch 2,17	1,18	4,35	3,94	0,43	2,72	2,36	4,33	4,37	2,99	0,98	0,53	0,33	0,37	2,01	3,64	1,77	1,73	0,51	0,71	0,35	0,51	lb 5,26	
GPK2	20	MPa 35	mm 70	38,5	129	118	14	88,5	70	180	121,5	90	29	16,5	10,5	11,5	60	108,5	51	52	20	21	14	20	kg 4,079	GP200T43011A000
		Psi 5075	inch 2,76	1,52	5,08	4,65	0,55	3,48	2,76	7,09	4,78	3,54	1,14	0,65	0,41	0,45	2,36	4,27	2,01	2,05	0,79	0,83	0,55	0,79	lb 8,99	
GPK2	25	MPa 35	mm 79,5	44	146	135	14	98	80	180	131	105	34,9	16,5	10,5	9	67	124	60	61,25	25	24	14	25	kg 5,883	GP200T53011A000
		Psi 5075	inch 3,13	1,73	5,75	5,31	0,55	3,86	3,15	7,09	5,16	4,13	1,37	0,65	0,41	0,35	2,64	4,88	2,36	2,41	0,98	0,94	0,55	0,98	lb 12,97	
GPK2	32	MPa 35	mm 105,5	58,75	183,5	165	14	124	100	300	124	124	39,7	19	13	11	79	147	78	74	32	28	17	32	kg 12,169	GP200T63011A000
		Psi 5075	inch 4,15	2,31	7,22	6,50	0,55	4,88	3,94	11,81	4,88	4,88	1,56	0,75	0,51	0,43	3,11	5,79	3,07	2,91	1,26	1,10	0,67	1,26	lb 26,83	
GPK2	40	MPa 35	mm 115	61,25	201,5	185	14	133,5	130	300	134	141	47,7	25	16,5	29	85	141	95	85	37	24	17	40	kg 18,624	GP200T73011A000
		Psi 5075	inch 4,53	2,41	7,93	7,28	0,55	5,26	5,12	11,81	5,28	5,55	1,88	0,98	0,65	1,14	3,35	5,55	3,74	3,35	1,46	0,94	0,67	1,57	lb 41,06	
GPK2	50	MPa 35	mm 129	72	256,5	240	14	147	150	300	147,5	174	59,8	31	21	38	106	174	112	106	48	38	17	48	kg 30,644	GP200T83011A000
		Psi 5075	inch 5,08	2,83	10,10	9,45	0,55	5,79	5,91	11,81	5,81	6,85	2,35	1,22	0,83	1,50	4,17	6,85	4,41	4,17	1,89	1,50	0,67	1,89	lb 67,56	

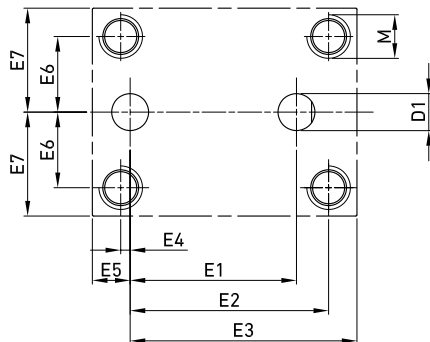

## DRILLING PATTERN FOR DN6 TO DN10

DN	D1	E1	E2	E3	E4	E5	E6	E7	M	O-RING	
6	mm	6	35	34,5	48,5	0,5	9,5	13,5	20	M6	7,30 X 2,40
	inch	0,24	1,38	1,36	1,91	0,02	0,37	0,53	0,79		
10	mm	9,5	44	52,5	60	2,5	10	20	27,5	M8	9,92 X 2,62
	inch	0,37	1,73	2,07	2,36	0,10	0,39	0,79	1,08		

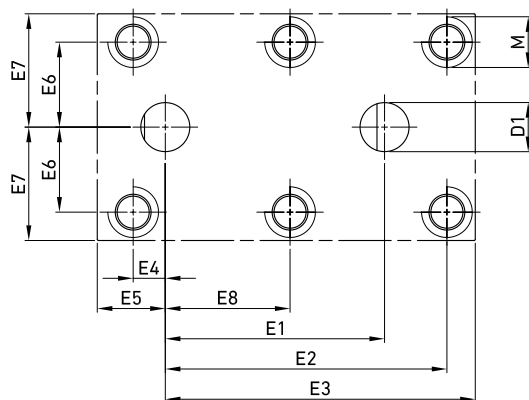

## DRILLING PATTERN FOR DN13 TO DN50

DN	D1	E1	E2	E3	E4	E5	E6	E7	E8	M	O-RING	
13	mm	13	58	74,5	82	8,5	18	22,5	30	33	M8	20,64 X 2,62
	inch	0,51	2,28	2,93	3,23	0,33	0,71	0,89	1,18	1,30		
20	mm	20	69	87,5	97	9,5	21	25,5	35	39	M10	23,81 X 2,62
	inch	0,79	2,72	3,44	3,82	0,37	0,83	1,00	1,38	1,54		
25	mm	25	81	100	111	15	24	30	40	43	M10	31,42 X 2,62
	inch	0,98	3,19	3,94	4,37	0,59	0,94	1,18	1,57	1,69		
32	mm	32	96	119	137	17	28	39	50	51	M12	34,59 X 2,62
	inch	1,26	3,78	4,69	5,39	0,67	1,10	3,07	1,97	2,01		
40	mm	37	-	112	156	-	29	47,5	65	56	M16	42,52 X 2,62
	inch	1,46	-	4,41	6,14	-	1,14	1,87	2,56	2,20		
50	mm	48	-	136	202	-	38	56	75	68	M20	53,64 X 2,62
	inch	1,89	-	5,35	7,95	-	1,50	2,20	2,95	2,68		