

GEMELS VALVES FOR CNG



VALVES FOR CNG APPLICATION

Thanks to the close collaboration with technical department and the engineering department of our customers, **GEMELS** is able to study the best and most suitable solution for the application where our products will be mounted. **GEMELS** can realize prototypes and samples. Our customized solutions can range over different fields, like fire-fighting, CNG, construction, building, marine but also lifting, automotive, steel plant, heavy equipment and agriculture.



HIGH CYCLICITY

After many resistance tests, a specific product has been studied that reaches 1.000.000 cycles.



HIGH PRESSURE

Gemels is specialist in design and manufacture high pressure ball valve



COMPACT DIMENSIONS

Particular attention to save space and reduce the overall dimension



SOLUTIONS AVAILABLE



SBF

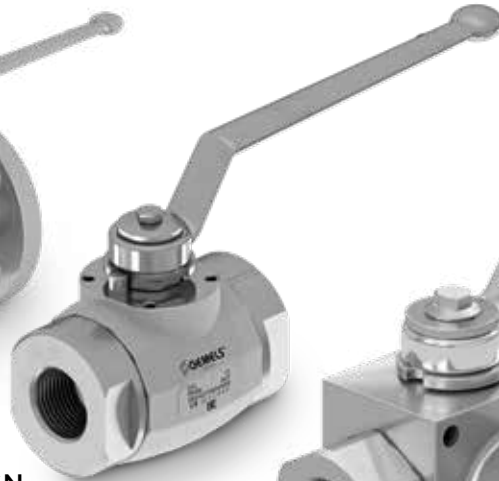

GN



GE3



GE2



SBF-W



GE2HC



LEAN SOLUTION

Special lean solution designed according to specific request.



In GEMELS range of products there are valves manual and actuated specific for the installation on CNG compressed natural gas distribution systems and compressors.

MORE TYPES AVAILABLE FOR DIFFERENT APPLICATIONS



GEMELS S.p.A. (Headquarters)

Via Gambirasio, 20/22
24069 Trescore Balneario (Bergamo) - ITALY
tel. (+39) 035 940 445 fax. (+39) 035 945 205
gemels@gemels.it

GEMELS NORTH AMERICA INC.

Billing Address
1800 West Loop South - Suite 1740 - Houston, TX 77027
Warehouse & Distribution Center
2351 US Route 130 - Dayton, NJ 08810
northamerica@gemels.com
www.gemels.com



gemels.it

